

Type EDC, 70 °C Long Life Electric Double Layer Supercapacitor



Type EDC, 70 °C electric double layer supercapacitors offer high capacitance values in a thru hole stacked coin type package. Primarily designed for integrated circuit voltage backup, the capacitors can also be used to deliver the initial power from batteries.

Highlights

- Long life
- High discharge current
- 70 °C Operating temperature

Specifications

Operating Temperature Range	-25 °C to +70 °C
Rated Voltage Range	5.5 Vdc to 6.3 Vdc
Capacitance Range	0.047 F to 1.5 F
Life, Moisture and Temperature Characteristics	After the following procedures have been performed, measure the capacitance and ESR at +20 °C.
Life Test:	Apply the max. operating voltage for 1000 h at +70 °C
Capacitance Change	±30% of the initial measured value
ESR	≤ 4 times the initial specified value
Shelf Life:	Subject the capacitor to 1000 hours without voltage at +70 °C.
Capacitance Change	±30% of the initial measured value
ESR	≤ 4 times the initial specified value
Moisture Resistance:	Subject the capacitor to 240 hours at +40 °C at 90 to 95% RH without voltage.
Capacitance Change	±30% of the initial measured value
ESR	≤ 3 times the initial specified value
Temperature Cycling	Stabilize the capacitor at each of the following temperatures for 1 hour in sequence, and then measure the capacitance and ESR at that temperature.
	1. +20 °C 2. -25 °C 3. +20 °C 4. +70 °C 5. +20 °C
Capacitance Change (at -25 °C)	±30% of the initial measured value
ESR (at -25 °C)	≤ 5 times the initial measured value
Capacitance Change (at +85 °C)	±30% of the initial measured value
ESR (at +85 °C)	≤ 4 times the initial measured value
Capacitance Change (Step 5 at +20 °C)	±10% of the initial measured value
ESR (Step 5 at +20 °C)	meets the initial specified value
RoHS Compliant without Exemptions	

Type EDC, 70 °C Long Life Electric Double Layer Supercapacitor Ratings

5.5 VDC					
CDE Part Number	Cap F	ESR 1 kHz Ω	Case Code		
			V Type	H Type	C Type
EDC473Z5R5*	0.047	120	V1	H1	C1
EDC104Z5R5*	0.1	75	V1	H1	C1
EDC224Z5R5*	0.22	75	V1	H1	C1
EDC334Z5R5*	0.33	75	V1	H1	C1
EDC474Z5R5*	0.47	50	V1	H1	C1
EDC105Z5R5*	1	30	V2	H2	C2
EDC155Z5R5*	1.5	30	V2	H2	C2

*V, H, or C

6.3 VDC			
CDE Part Number	Cap F	ESR 1 kHz Ω	Case Code
EDC104Z6R3C	0.1	120	C3
EDC224Z6R3C	0.22	75	C3
EDC334Z6R3C	0.33	75	C3
EDC474Z6R3C	0.47	50	C4
EDC684Z6R3C	0.68	50	C4
EDC105Z6R3C	1	30	C4

Part Numbering System

EDC
Series

224
Capacitance
224 = 0.22 F
473 = 0.047 F
105 = 1.0 F

Z
Tolerance
-20/+80%

5R5
Voltage
5R5 = 5.5 Vdc

C
Case Style
C = Radial
H = Horizontal Style
V = Vertical Style

EDC Outline Drawing

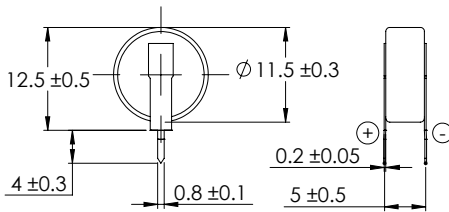

V1

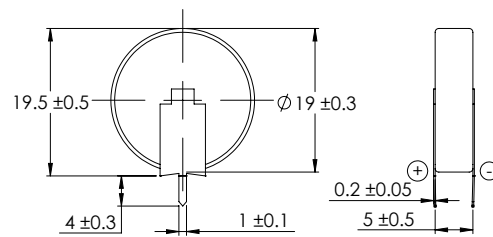

V2

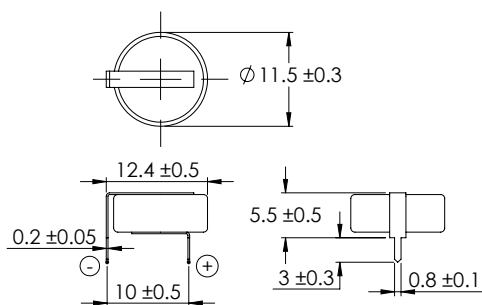

H1

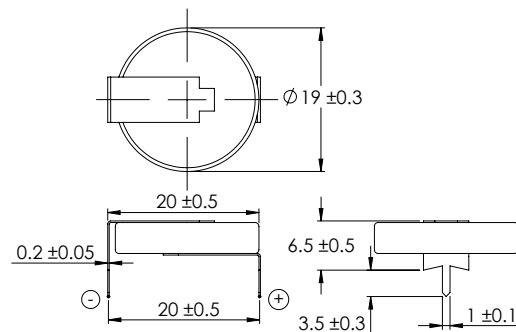

H2

Type EDC, 70 °C Long Life Electric Double Layer Supercapacitor

EDC Outline Drawing

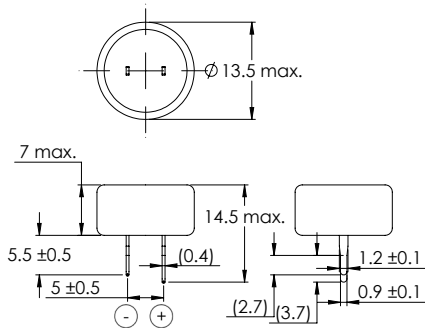

C1

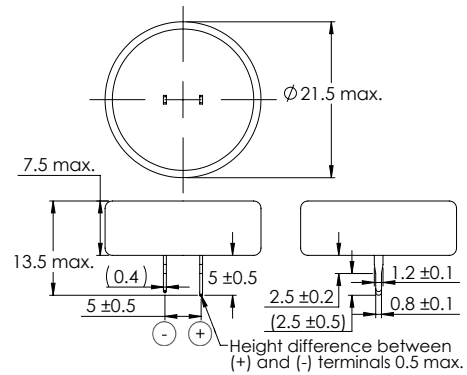

C2

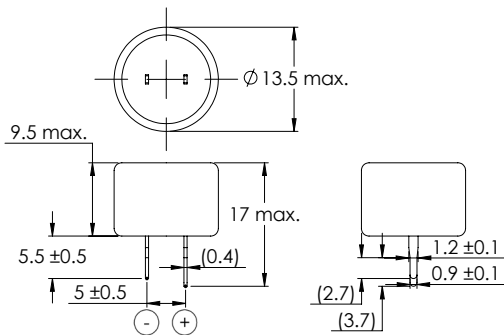

C3

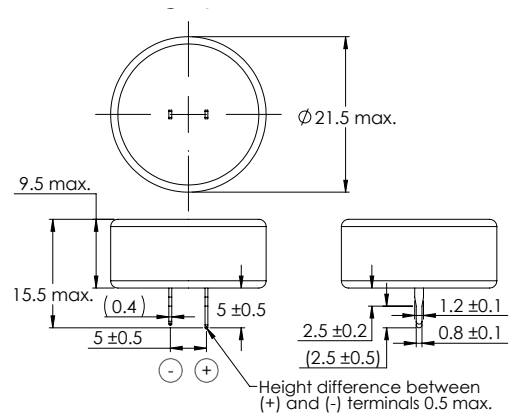

C4

Recommended Soldering Procedures

Hand Soldering	Use a 30W iron with a max. temperature of 350 °C for 3 seconds.
Wave Soldering	Pre-heat circuit board to a surface temp of 110 °C for a max. of 60 seconds, with a max. component temperature of 100 °C. Min. printed circuit board thickness of 0.8 mm. Recommended solder bath temperature of 240 °C with a max. dipping time of 5 seconds.

Notice and Disclaimer: All product drawings, descriptions, specifications, statements, information and data (collectively, the "Information") in this datasheet or other publication are subject to change. The customer is responsible for checking, confirming and verifying the extent to which the Information contained in this datasheet or other publication is applicable to an order at the time the order is placed. All Information given herein is believed to be accurate and reliable, but it is presented without any guarantee, warranty, representation or responsibility of any kind, expressed or implied. Statements of suitability for certain applications are based on the knowledge that the Cornell Dubilier company providing such statements ("Cornell Dubilier") has of operating conditions that such Cornell Dubilier company regards as typical for such applications, but are not intended to constitute any guarantee, warranty or representation regarding any such matter – and Cornell Dubilier specifically and expressly disclaims any guarantee, warranty or representation concerning the suitability for a specific customer application, use, storage, transportation, or operating environment. The Information is intended for use only by customers who have the requisite experience and capability to determine the correct products for their application. Any technical advice inferred from this Information or otherwise provided by Cornell Dubilier with reference to the use of any Cornell Dubilier products is given gratis (unless otherwise specified by Cornell Dubilier), and Cornell Dubilier assumes no obligation or liability for the advice given or results obtained. Although Cornell Dubilier strives to apply the most stringent quality and safety standards regarding the design and manufacturing of its products, in light of the current state of the art, isolated component failures may still occur. Accordingly, customer applications which require a high degree of reliability or safety should employ suitable designs or other safeguards (such as installation of protective circuitry or redundancies or other appropriate protective measures) in order to ensure that the failure of an electrical component does not result in a risk of personal injury or property damage. Although all product-related warnings, cautions and notes must be observed, the customer should not assume that all safety measures are indicated in such warnings, cautions and notes, or that other safety measures may not be required.